

ROTARY TILLER

Product Manual

MODEL :GLD91TMZ



Table of contents

Introduction	3
Safety	4
. Safety	
. General Safety.....	5
. Start-up Safety.....	5
. Operation Safety.....	5
. Transport Safety.....	6
. Service and Maintenance Safety.....	6
. Storage Safety.....	6
MachineComponents	7-13
Assembly	14
. Assembly Instructions.....	14
Start-up	15
. Machine Break-in.....	15
. Pre-operation Checklist.....	15
Operation	16
. Equipment Matching.....	16
. Shortening a PTO Driveline.....	16
. Attaching/Unhooking.....	17
. Transporting.....	18
. Storage.....	19
Maintenance	20
. Service.....	20
. Fluids and Lubricants.....	20
. Greasing.....	20

Introduction

The Tiller suits your garden and landscaping needs. Tiller attaches to the 3-point hitch as well as our Cat. 1 Quick Hitch and is designed to fit a variety of tractors from 45 hp to 55 hp.

The skid shoes are adjustable so it is easy to set the perfect tilling depth. The automatic chain tightener is standard on all models. This ensures the chain remains tight even under the toughest tilling conditions. Housing within a sealed oil bath, the chain tightener is designed to be reliable and maintenance-free. Getting close to the fences, hedges or covering a tire track is easy with the side shift feature. The entire unit can be pushed to one side, while the PTO shaft remains in line with the tractor to minimize stress on the universal joint. The side shift feature is available.

Thoroughly read and understand the instructions given in this manual before operation. Refer to the "Safety Label" section, read all instructions noted on them. Do not allow anyone to operate his equipment who has not fully read and comprehended this manual and who has not been properly trained in the safe operation of the equipment.

Safety

Safety Instructions

The operator must read the operation manual carefully before installation, operation or maintenance. Improper operation will cause the machine damage or the operator death.

Make these practices a working part of your safety program.

Be certain that everyone operating this equipment is familiar with the recommended operating and maintenance procedures and follows all the safety precautions. Most accidents can be prevented. Do not risk injury or death by ignoring good safety practices.

The alert symbol is used throughout this manual. It indicates attention is required and identifies hazards. Follow the recommended precautions.



The Attention symbol indicates a potentially hazardous situation that, if not avoided, may result in minor or moderate injury.



The Warning Symbol indicates a potentially hazardous situation that if not avoided, could result in death or serious injury.



The Danger Symbol indicates an imminently hazardous situation that, if not avoided will result in death or serious injury.

Safety

General Safety Instructions

- . Have a first-aid kit available for use and know how to use it.
- . Have a fire extinguisher available, stored in a highly visible location, and know how to use it.
- . Wear appropriate protective gear. This list may include but is not limited to:
 - hard hat
 - protective shoes with slip resistant soles
 - protective glasses or goggles
 - heavy gloves
 - wet weather gear
 - hearing protection
 - respirator or filter mask
- . Read and understand the Operator's Manual and all safety signs before operating, servicing, adjusting, repairing, or unplugging the equipment.
- . Do not attempt any unauthorized modifications to your Farm King product as this could affect function or safety, and could affect the life of the equipment.
- . Never start or operate the mower except from the operator's station on the power unit.
- . Inspect and clean the working area before operating.
- . Keep hands, feet, clothing, and hair away from moving parts.
- . Ensure bystanders are clear of the area before operating.

Start-up Safety

- . Wear protective clothing and equipment appropriate for the job.
- . Place all tractor and machine controls in neutral before starting.
- . Operate only with ROPS and seatbelt equipped tractors.
- . Do not operate inside a building unless there is adequate ventilation.
- . Ensure all shields are in place and in good condition before operating.
- . Stay clear of PTO shaft and machine when engaging PTO.

Operation Safety

- . Do not permit riders.
- . Do not wear loose fitting clothing during operation.
- . Never operate over 540 PTO rpm speed.
- . Never operate the equipment in the raised position.

Safety

Transport Safety

- . Review Transport Safety instructions in tractor manual before moving.
- . Check with local authorities regarding transport on public roads. Obey all applicable laws and regulations.
- . Make sure the SMV (Slow Moving Vehicle) emblem and all the lights and reflectors that are required by the local highway and transport authorities are in place, are clean, and can be seen clearly by all overtaking and oncoming traffic.
- . Never have the equipment in operation during transport.
- . Always travel at a safe speed.

Service and Maintenance Safety

- . Stop engine, set brake, remove ignition key, and wait for all moving parts to stop before servicing, adjusting, repairing, or unplugging.
- . Support the equipment with blocks or safety stands before working beneath it.
- . Follow good shop practices including:
 - keep service area clean and dry
 - be sure electrical outlets and tools are properly grounded
 - use adequate light for the job
- . Use only tools, jacks, and hoists of sufficient capacity for the job.
- . Replace and secure all shields removed during servicing before operating.
- . Use heavy leather gloves to handle sharp objects.

Storage Safety

- Store the unit in an area away from human activity.
- Store machine and fuel where fuel vapors cannot reach sour combustion like, water heaters, electric motors, switches, furnaces, etc. .
- Always secure the machine with tie downs or similar restraints when transporting.
- The machine be stored in a manner that prevents it from falling, rolling or tipping.

Machine Components

Main panel exploded view

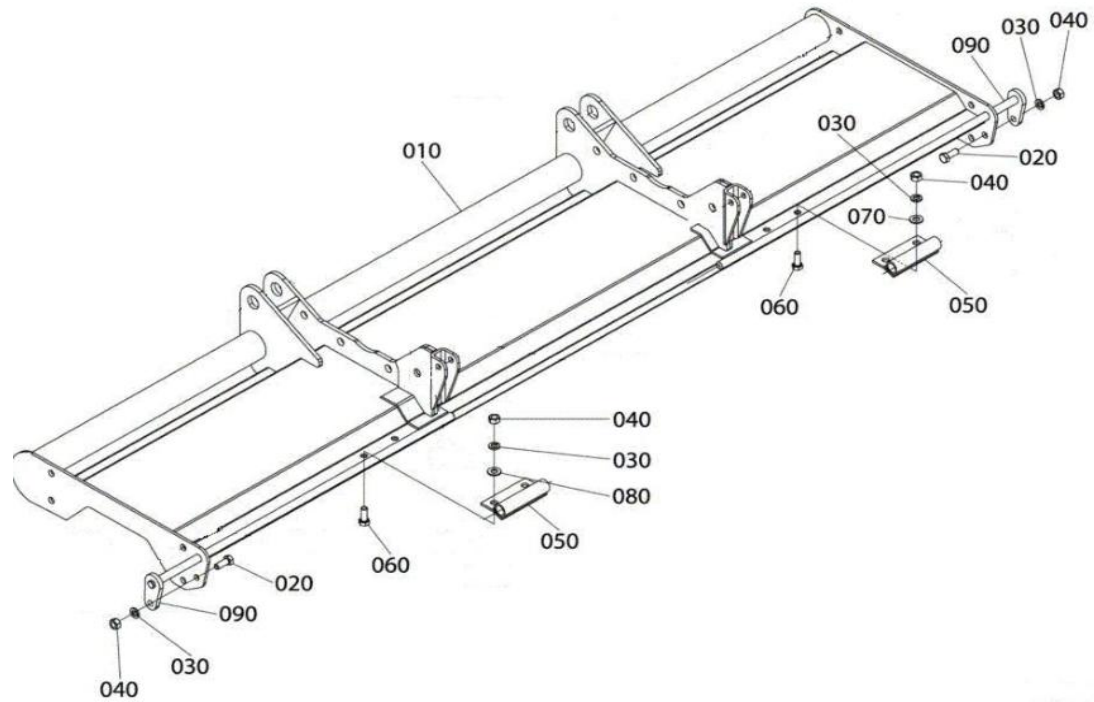

S/N	PART DESCRIPTION	NOTE
010	Front beam tube	
020	Screw	M8*40
030	Spring pad	φ 8
040	Nut	M8
050	Hinge	
060	Screw	M12*35
070	Flat pad	φ 12
080	Flat pad	φ 12
090	Through shaft assembly	

PTO SHAFT exploded view

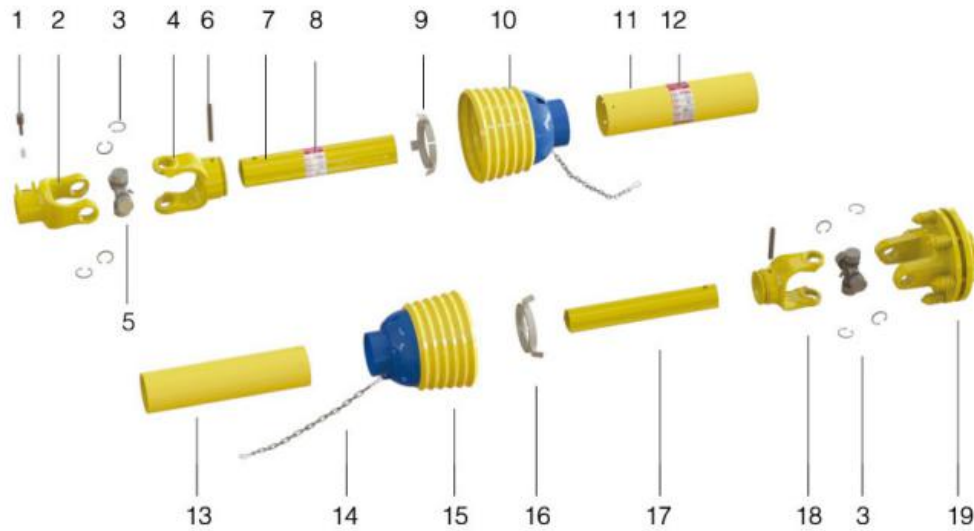

S/N	PART DESCRIPTION	S/N	PART DESCRIPTION
1	Pin kit	11	Outer shield tube
2	End yoke for tractor side	12	Safety label for outer shield tube
3	Cross journal with four circlips	13	Inner shield tube
4	Outer tube yoke	14	Safety chain
5	U-joint assembly	15	Inner shield cone
6	Tension pin	16	Inner shield bearing
7	Outer tube	17	Inner tube
8	Safety label for telescoping tube	18	Inner tube yoke
9	Outer shield bearing	19	Friction clutch
10	Outer shield cone		

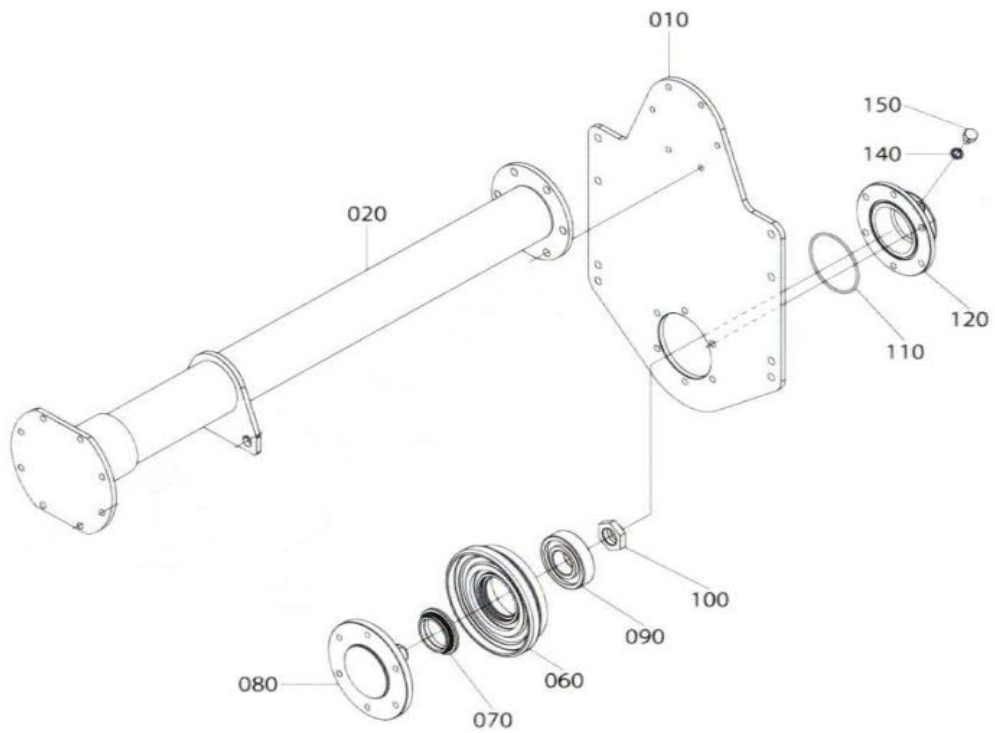

S/N	PART DESCRIPTION	NOTE
010	Fixed side panels	
020	Fixed arm assembly	
060	Fixed side bearing housing	
070	Floating oil seal	
080	Fixed side flange shaft	
090	Bearing	6308
100	Shaft lock nut	
110	Shaft cover bowl gasket	
120	Fixed side shaft head cover bowl	
140	Combination washer	12mm
150	Oil plug	12*1.5mm

PTO SHAFT side exploded view

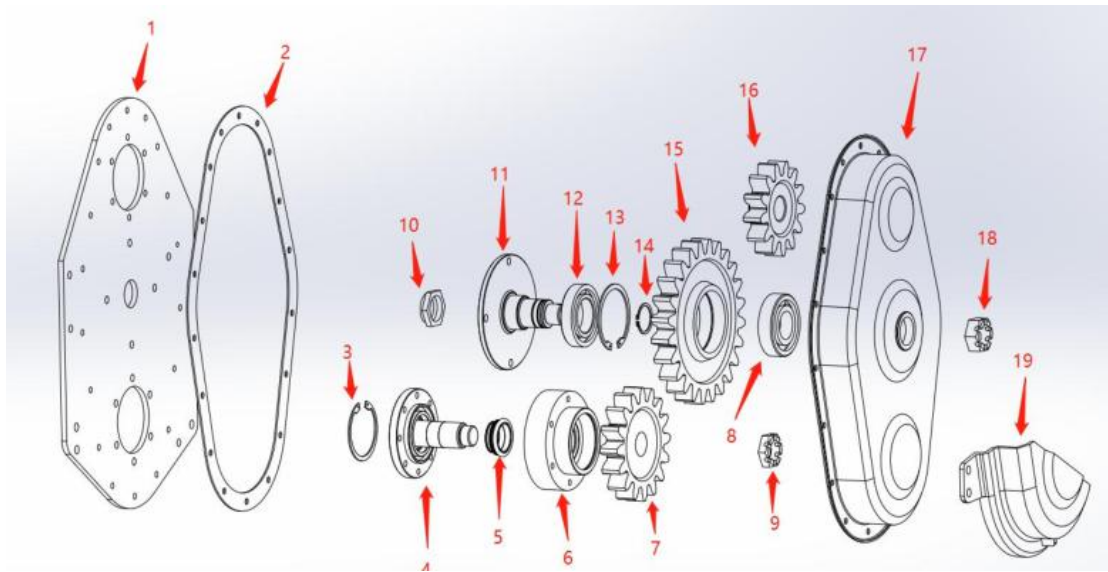

S/N	PART DESCRIPTION	NOTE
1	Drive side plate	
2	Rubber gasket	
3	Circlip	
4	Tool shaft drive flange shaft	
5	Floating oil seal	BUF62
6	Cutter shaft drive shaft	Bearing 6309
7	Driven gear	
8	Bearing	6310
9	Flowering nut	
10	Screw nut	
11	Intermediate drive shaft	O Ring size 50*3.1mm
12	Bearing	6212
13	Circlip	hole 110
14	Circlip	Axle 45
15	Intermediate gear	
16	Gear	
17	Side gearbox cover	
18	Flowering nut	
19	Side Gearbox Housing Guard	

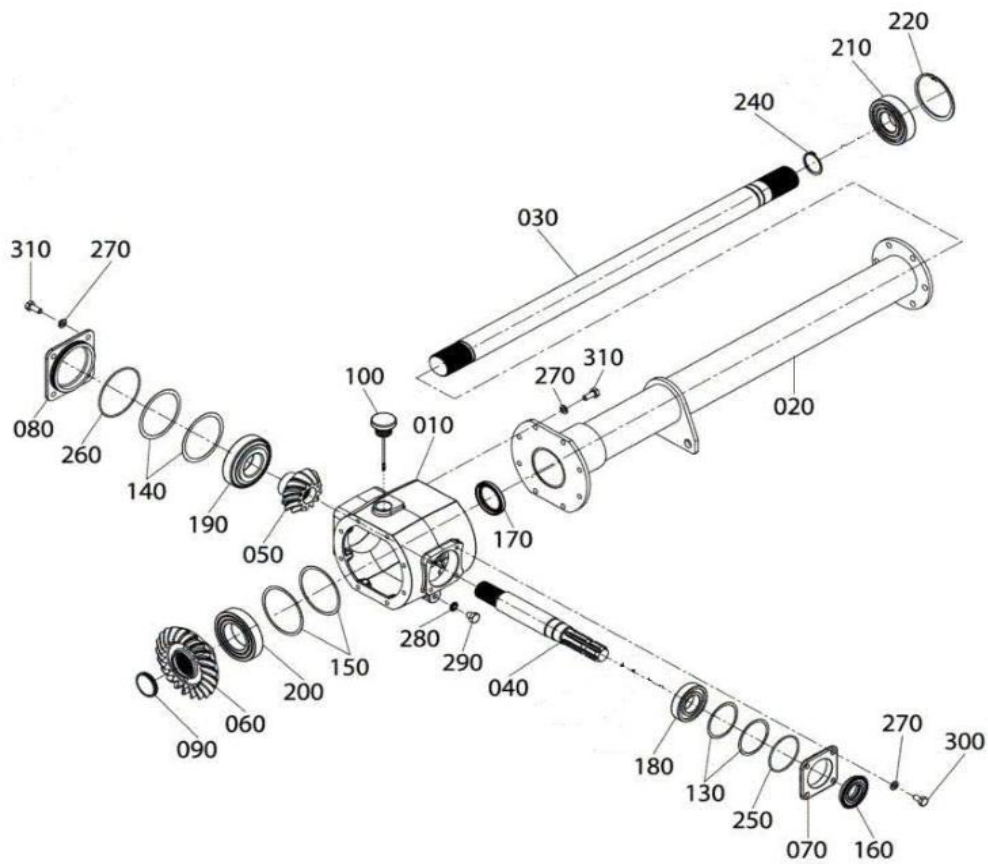

S/N	PART DESCRIPTION	NOTE
010	Body box	
020	Transmission arm tube assembly	
030	Transmission half shaft	
040	Input shaft	
050	Gear 12 teeth	
060	Gear 22 teeth	
070	Box front cover	
080	Box Back cover	
090	Stuffed cover oil seal	52mm
100	Vernier ruler	
130	Adjusting washer	
140	Adjusting washer	
150	Adjusting washer	

160	Oil seal	38*65*16mm
170	Oil seal	55*72*9mm
180	Bearing	30208
190	Bearing	30310
200	Bearing	
210	Bearing	6309
220	Circlip hole	100
240	Oil seal	50*72*12mm
250	Adjusting washer	
260	Adjusting washer	
270	Spring pad	φ10
280	Combination pad	12mm
290	Oil plug	M12*1.25
300	Screw	10*30*1.25
310	Screw	10*30*1.25

Cutter shaft exploded view

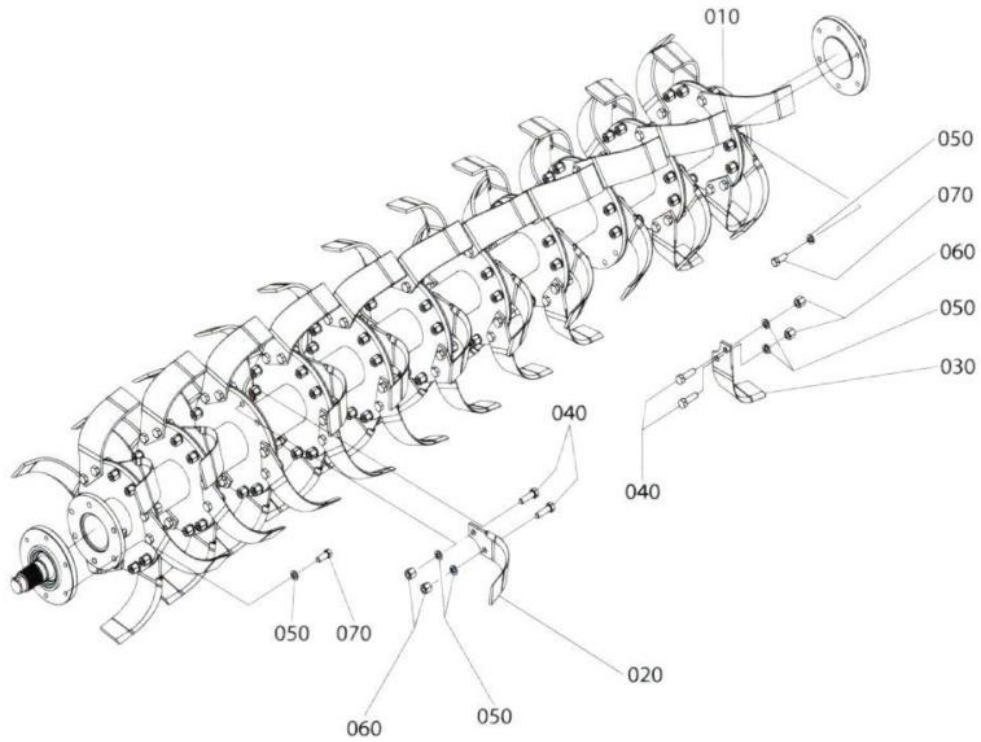

S/N	PART DESCRIPTION	NOTE
010	Cutter shaft flange	
020	Blade	
030	Blade	
040	Screw	12*35*1.25 mm
050	Spring pad	φ12
060	Nut	M12*1.25
070	Screw	12*35*1.25 mm

Assembly Instruction

The machine is shipped with the PTO shaft not installed.

To install the PTO driveline on the machine, follow this procedure.

1. Clear the area of bystanders, especially small children.
2. Clean the splines on the yoke and the input shaft.
3. Align the splines on the yoke and the shaft.
4. Attach the driveline to the tiller by removing the tapered pin and sliding the yoke onto the gearbox shaft. Line up the pin with the groove in the gearbox shaft and fasten with the tapered pin. The plastic gearbox PTO guard has a removable door on top to access the pin. The A-frame brace can be removed to improve accessibility. Replace the brace after tightening the nut on the tapered pin.
5. Be sure the yoke is locked in position. Pull on the yoke to be sure the pin clicks into position.
6. Be sure that the PTO shaft is the appropriate length for the tractor/Tiller combination.

Start up

Machine Break-in

Although there are no operational restrictions on the Tiller when used for the first time, it is recommended that the following mechanical items be checked:

- . After operating for 1/2 hour or after completing 1/2 acre:
 - Check all nuts, bolts and other fasteners. Tighten to their specified torque level.
 - Check that the blades are in good condition and bolted securely to the rotor.
 - Check the oil level in the gearbox. Add as required.
 - Check that the PTO driveline shield turns freely.
 - Lubricate all grease points.
- . After operating for 5 hours and 10 hours:
 - Repeat the items above.
 - Then go to the regular service schedule as defined in Section 5.

Pre-operation Checklist

Efficient and safe operation of the Rotary Tiller requires that each operator reads and understands the operating procedures and all related safety precautions outlined in this section. A pre-operation checklist is provided for the operator. It is important for both personal safety and maintaining the good mechanical condition of the Tiller that this checklist is followed.

- . Before operating the machine and each time thereafter, the following areas should be checked off:

- Lubricate the machine per the schedule outlined in the Service and Maintenance Section.
- Use only a tractor of adequate power and weight to pull the machine.
- Check that the machine is properly attached to the tractor. Be sure retainers are used on the mounting pins.
- Check the oil level in the gearbox. Add as required.
- Check that the PTO driveline shield turns freely and that the driveline can telescope easily. Clean and lubricate if required.
- Check the blades. Be sure they are not damaged or broken and are bolted securely to the rotor. Repair or replace as required.
- Remove any entangled material on rotating parts.
- Install and secure all guards, doors and covers before starting.
- The four socket set screws on the inside of the PTO clutch assembly must be turned

Operation Instruction

Equipment Matching

To insure the safe and reliable operation of the Tiller, it is necessary to use a tractor with the correct specifications. Use the following list as a guide in selecting a tractor to use on the machine.

1. Horsepower: Do not exceed the recommended horsepower levels. Use only small Agricultural tractors on this machine.
2. 3- Point Hitch: The Tiller is equipped with a Category 1, 3-point hitch. Be sure the tractor 3-point hitch is in the Category 1 configuration. Install the lift arm blocks or shorten the stop chains to place the arms into the non-sway configuration. Refer to the tractor manual for details.
3. Load Sensing Hydraulics: Many newer tractors are equipped with "Load Sensing" hydraulics. It is the responsibility of the operator to set the tractor hydraulic system to provide "float" on the 3-point hitch. The float feature will allow the machine to follow the ground contours during operation.
4. PTO Shaft: The tractor must have a 1-3/8" 6 spline 540 rpm PTO shaft to fit the driveline shaft supplied with the machine. Do not use shaft adapters or operate at any other speed. It is not recommended that a tractor with variable speed PTO's be used on the Tiller. Operating at speeds faster than 540 rpm will overload the drivetrain and lead to early failures.

Shortening a PTO Driveline

1. With the implement attached to the tractor's three point hitch, and the PTO driveline not installed, separate the PTO driveline. Attach the implement end to the implement and the other end to the tractor PTO input shaft.
2. Raise the implement by using the tractor's hydraulic 3-point hitch to it's maximum lift height.
3. Hold the half shafts next to each other and mark them so each end is approximately 1/2" from hitting the end of the telescopic profiles.
4. Shorten the inner and out guard tubes equally.
5. Shorten the inner and outer profiles by the same length as the guard tubes. Using a rat tail file, round off all sharp edges and burrs. Grease the telescopic profile generously before reassembling.

Operation Instruction

Attaching/Unhooking

The Tiller should always be located on a level, dry area that is free of debris and other foreign objects. When attaching the machine to a tractor, follow this procedure:

1. Clear the area of bystanders, especially small children.
2. Be sure the tractor 3-point hitch is in the Category 1 configuration and the lift arms are in the non sway configuration (See tractor manual).
3. Make sure there is enough room and clearance to safely back up to the Tiller.
4. Attach the PTO driveline to the Tiller if it was removed for storage (See Assembly).
5. While backing up, align the lift arm balls with the mounting pins on the Tiller.
6. Stop tractor, set park brake, remove ignition key and wait for all moving parts to stop before dismounting.
7. If your tractor is not equipped with a Quick Hitch:
 - Align the left lower link arm with the mounting pin. -- Slide the ball over the pin and install the Linch Pin.
 - Use the screw jack on the right lift arm to align the ball with the pin. -- Slide the ball over the mounting pin and install the Linch Pin.
 - Level the frame using the screw jack.
 - Remove the retainer and pin
 - Insert pin and install Linch Pin.
 - Level frame using the turnbuckle.
8. Use the 3-point hitch to raise the machine.
9. Remove the blocks from under the Depth Gauge Shoes.

Operation Instruction

Transporting

When transporting the machine, review and follow these instructions:

1. Be sure all bystanders are clear of the machine.
2. Be sure that the machine is securely attached to the tractor and all retainer pins are installed.
3. Clean the SMV emblem, lights and reflectors and be sure they are working.
4. Be sure you are in compliance with all applicable lighting and marking regulations when transporting. Check with your local authorities.
5. Be sure your machine can clearly be seen by overtaking and oncoming traffic.
6. Keep to the right and yield the right of way to allow faster traffic to pass. Drive on the road shoulder if permitted by law.
7. Do not allow riders.
8. Always use hazard flashers on the tractor when transporting unless prohibited by law.
9. Use pilot vehicles front and rear when transporting during times of limited visibility.
10. Never transport the machine faster than 20 mph (32 km/h). The ratio of the tractor weight to the Tiller weight plays an important role in defining acceptable travel speed. Table 2 summarizes the recommended travel speed to weight ratio.

Operation Instruction

Storage

After the season's use, the machine should be thoroughly inspected and prepared for storage.

Repair or replace any worn or damaged components to prevent any unnecessary down time at the start of next season. To insure a long, trouble free life, this procedure should be followed when preparing the unit for storage:

1. Clear the area of bystanders, especially small children.
2. Thoroughly wash the machine using a pressure washer to remove all dirt, mud, debris and residue.
3. Inspect the blades and rotors for damage or entangled material. Repair or replace damaged parts. Remove all entangled material.
4. Change the oil in the gear box.
5. Lubricate all grease fittings. Make sure that all grease cavities have been filled with grease to remove any water residue from the washing.
6. Touch up all paint nicks and scratches to prevent rusting.
7. Move to storage area.
8. Select an area that is dry, level and free of debris.
9. Place blocks under the Depth Gauge Shoes.
10. Unhook from tractor.

Maintenance

Service

Follow Maintenance Safety Instructions as outlined.

Fluids and Lubricants

1. Hydraulic Oil:

- Use standard hydraulic oil for all operating conditions.

2. Gear Box Oil:

- Use an SAE 85W90 gear oil for all operating conditions.
- Gear Box Capacity: 1 U.S. quart (0.85 liter)

3. Chain Case Grease:

- Use a multi-purpose grease for all operating conditions.
- If chain case is removed, refill with 80 grams of grease.

4. Storing Lubricants:

- Your machine can operate at top efficiency only if clean lubricants are used. Use clean containers to handle all lubricants. Store them in an area protected from dust, moisture and other contaminants.

Greasing

Use a Maintenance Checklist to keep a record of all scheduled maintenance.

1. Use a hand held grease gun for all greasing.

2. Wipe grease fitting with a clean cloth before greasing, to avoid injecting dirt and grit.

3. Replace and repair broken fittings immediately.

4. If fittings will not take grease, remove and clean thoroughly. Also clean lubricant passageway. Replace fitting if necessary.

CUSTOMER INFORMATION

NAME: _____

PURCHASED FROM: _____

DATE OF PURCHASE: _____

MODEL NUMBER: _____

SERIAL NUMBER: _____